

After Power ON, the Status LED on a Clevertest Plus enabled fitting will display a rapid Green or Red flashing for a period up to 2 minutes.

**Zoneworks, HIVE (HV/HVG) and DATA Monitored Options**

Fittings with part numbers -ZW, -HV, -HVG, -DATA are fitted with Zoneworks communications modules (nodes). These fittings are monitored using either Powerline Carrier Technology that utilize the power cable to provide data communication, RF transceiver modules operating in the ISM band or a dedicated data cable to/from data routers installed on a dedicated data trunk connected to a central Server (can also be connected via Ethernet/Internet/Fibre). Zoneworks software on the server is used to monitor, coordinate testing and collate test data from each fitting. Zoneworks Fittings can be commissioned by a single push of the test switch or by scanning the supplied barcode. The LED Test Switch indicator provides a multifunction indication of the status of the fitting during testing and normal operation.

Option	State	LED Operation
ZW, HV, HVG, DATA	Commissioned	LED on Solid (Green)
ZW, DATA	Un-commissioned	<b>Batt plugged-in:</b> yellow 1s, green 1s
		<b>Batt unplugged:</b> red 1s, off 1s
HV, HVG	Un-commissioned With network connectivity	<b>Batt plugged-in:</b> yellow 1s, green 1s
		<b>Batt unplugged:</b> red 1s, off 1s
HV, HVG	Un-commissioned Without network connectivity	<b>Batt plugged-in:</b> yellow 250mS, green 250mS, yellow 250mS, green 250mS, green 1s
		<b>Batt unplugged:</b> red 250mS, off 250mS, red 250mS, off 250mS, off 1s
ZW, DATA	Emergency Light Test In Progress	LED flashes at yellow 5s , Off 1s
HV, HVG	Emergency Light Test In Progress	LED flashes at yellow 1s , Off 1s

In the case of the DATA version a 2-way "figure 8" cable and terminal block facilitates the connection to the DATA network via a multi-drop bus (daisy chain connection). For further information of installation of a Zoneworks system, please refer to the Zoneworks Users Guide and Commissioning Guide (incl. DATA version)

**DALI EM Option**

Luminaires with part numbers having -DALI are fitted with DALI modules (nodes) that facilitate connection and integration to 3<sup>rd</sup> Party Lighting Control Systems. Before installing the -DALI luminaire, please confirm that the Lighting Control System has the capability to monitor DALI Emergency Luminaires. The -DALI fitting will be addressed and configured into the control system by the Lighting Control System Commissioning Technicians and not Clevertronics.

State	LED Operation
Commissioned/ Un-commissioned	LED on Solid (Green)
Emergency Light Test in progress	LED flashes at 1s On (Yellow) & 1s Off
"IDENTIFY COMMAND"	Lamp and Status LED Flash for 30 seconds

A 2-way "figure 8" cable and terminal block facilitates the connection to the DALI network. DALI connections are marked as Da Da.



**LP™ LIFELIGHT Recessed Splash Proof  
Emergency Light**

**Installation & Maintenance Instruction Leaflet**



**Designed in Australia to comply with the requirements of AS2293.3: 2005 and AS/NZS CISPR15: 2011.**

NOTE: Standard product codes with this symbol  are enabled with Clevertest Plus capability. Please refer to the operation guide supplied with the product for details.

**Victoria (Head Office & Manufacturing)**

Website: [www.clevertronics.com.au](http://www.clevertronics.com.au)

Email: [info@clevertronics.com.au](mailto:info@clevertronics.com.au)

Phone: +61 3 9559 2700

Fax: +61 3 9559 2799

**News South Wales**

Phone: +61 2 8805 6400

Fax: +61 2 8805 6444

**Queensland**

Phone: +61 7 3442 9700

Fax: +61 7 3442 9777

**South Australia/Northern Territory**

Phone: +61 8 8301 8800

Fax: +61 8 8351 8286

**Western Australia**

Phone: +61 8 9207 0000

Fax: +61 8 9207 0088

**New Zealand**

Phone: +64 800 548 448

**Models:**

**CLIFE-RECSP-zz-xx-yy-vv-ss**

**Testing:**

Manual Test xx = Blank  
 Zoneworks xx = ZW  
 Zoneworks DATA xx = DATA  
 Zoneworks HIVE xx = HV/HVG  
 DALI Registered xx = DALI  
 Clevertest xx = CT

**Options:**

4 Hour runtime vv=4HR  
 Corridor Lens zz=CL  
 Tamper Proof yy = TP  
 Custom Colour ss = CC



(NOTE: -CT Products supplied with the Clevertest Plus Symbol  are activated with Clevertest PLUS capability. Please refer to the operation guide supplied with the product for details).

**Spare Parts:**

1100760 Replacement Emergency LED Lamp  
 1100759 Replacement Emergency LED Lamp (-CL)  
 1550010 Replacement Battery  
 1550230 Replacement Battery (-4HR)  
 AUM02370010001 Replacement Emergency Driver  
 AUM02870080001 / AUM02970020001 Replacement Emergency Driver (-HV / -HVG)  
 AUM02270150102 Replacement Emergency Driver (-DALI)

**Important:**

It is illegal for anyone, except for a licensed electrician to install or maintain this product. Before installation, ensure that the electricity supply has been switched off and isolated. Installation must be carried out in accordance with the relevant Australian and International Standards.

## Installation:

This CLIFE-RECSF Recessed Non-maintained Emergency can be installed on PLASTER or T-BAR ceilings or used to replace an existing unit.

- First plan the assembly layout ensuring the battery is kept away from any heat source.
- Refer Images and Dimensions below for the Cut-out Hole and other dimensions.
- For products requiring a Corridor or Area Lens, replace Lens now (see below)
- Use the two Spring Legs to mount the Head into the ceiling. **IMPORTANT:** Ensure Heads are firmly fitted flush with the mounting surface to ensure water resistance. (See IP Ratings)
- Please ensure the control pack and battery is suspended above the ceiling. If the control pack and battery are to be mounted or placed on top of the ceiling, then please ensure the ceiling can support these elements and in compliance with the relevant regulations with respect to mounting above/on the ceiling.
- If the CTP capabilities are activated, please affix the CTP status label to a visible surface and mark an "F" in third segment of the Four Segment Marking 

X	0	ADF	120
---	---	-----	-----

## Images and Dimensions:

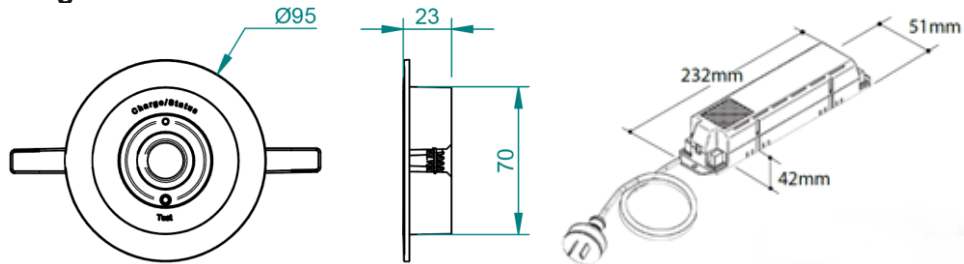

Ceiling Cut-out: 80mm diam.

Battery pack: 160mm (L) x 47mm (W) x 25mm (H)

## Lens Replacement

- STEP 1 - Use a screwdriver to remove the Bezel, Gasket & Lens (Bezel clips highlighted below).
- STEP 2 - Replace Lens (for corridor Lens align the locating pins as indicated below)
- STEP 3 - Replace Bezel & Gasket (ensure Bezel is pressed firmly to ensure a proper seal)

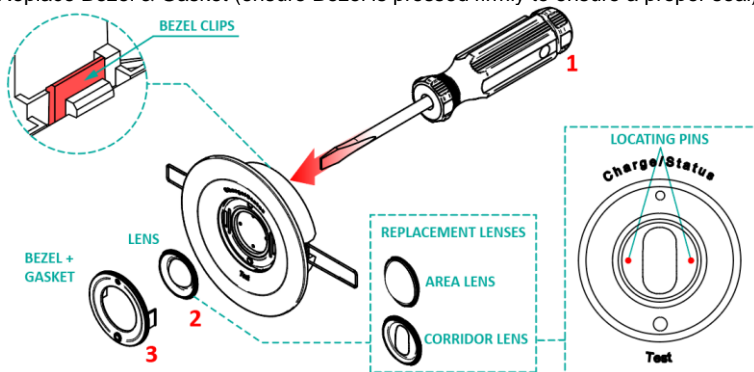

## IP Ratings:

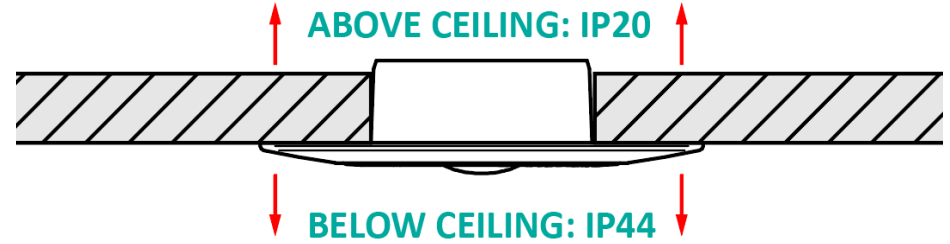

## Testing:

When the Lifelight unit is connected to the un-switched active, it must be allowed to charge the battery for at least 24 hours. The emergency lamp only illuminates during a power fail. Conduct the following tests:

- The emergency lamp must illuminate for at least 2 hours after disconnection from the mains. The results of all tests are required to be recorded in a service logbook, which is to be kept on-site at all times. If the unit fails to illuminate for the requisite time, remedial action must be taken to repair the situation and once completed, the unit must pass a subsequent test.
- Press and hold Test Button or switch Off Mains Supply, check that the emergency lamp is On.
- Release the Test Button or Switch On Mains Supply, check that the emergency lamp is Off (Non-maintained operation).

## Below are a list of common problems and their possible causes:

**Fault:** The Green LED indicator is not illuminated.

**Check:** A.C. is connected and is turned on.  
Battery is connected.  
Test Switch for damage.

**Fault:** Lamp does not illuminate in emergency mode.

**Check:** A.C. is connected.  
Lamp is correctly inserted.  
Battery is connected

**Fault:** Lamp illuminates in emergency mode, but only stays on for a short period.

**Check:** Battery has been allowed to charge for at least 24 hours.  
Battery for damage.

## Rated Emergency Lumen Output in accordance with AS2293.1 (refer to spacing tables for installation positions):

Refer to the Technical Label for classification information.

## Caution:

On many building sites, power circuits may be cut off in an uncontrolled and repetitive basis during construction. As a result, any Lifelight Units, on these circuits, will have their batteries discharged or "cycled". The Li-ion battery in the Lifelight has been selected to give excellent long life performance in a controlled IEC 60598-2-22 testing environment. Excessive battery cycling will reduce through-life performance and may lead to premature battery failure. Battery warranty claims, as a result of such abuse, are specifically EXCLUDED from Clevertronics warranty terms.

## Warranty:

For Product Warranty information and Terms and Conditions of Sales please refer to our website <http://clevertronics.com.au/terms-conditions-sale-australia-nz/>